

目 录

- 1、适用范围 **APPLICATION**
- 2、规格特性 **SPECIFICATIONS & CHARACTERISTICS**
 - 2.1 基本规格 **BASIC SPECIFICATIONS**
 - 2.2 性能 **PERFORMANCE**
 - 2.3 电气配件 **ELECTRICAL COMPONENT**
 - 2.4 过载保护器特性 **OVERLOAD PROTECTOR PROPERTY**
 - 2.5 使用条件 **APPLICATION CONDITION**
 - 2.6 安装附件 **MOUNTING ACCESSORIES**
 - 2.7 压缩机相关图纸 **COMPRESSOR RELATED DRAWINGS**
- 3、压缩机使用注意事项 **COMPRESSOR CAUTIONS**
- 4、附件及图纸 **ACCESSORIES & DRAWINGS**

1、适用范围 APPLICATION

此规格书适用于 (YZG-A112Y4) 全封闭式压缩机

This specification is applied to (YZG-A112Y4) rotary compressor

名称 Name	规格 Specification
冷媒 Refrigerant	R134a
环境温度使用范围 Range of Ambient Temperature	-5~50℃
冷媒充注量 Allowable amount of refrigerant charge	350g
额定电压/频率/相数 Rated Voltage / Frequency / Phase	220V-240V ~ /50Hz/1Φ

2、规格特性 SPECIFICATIONS & CHARACTERISTICS

2.1 基本规格 BASIC SPECIFICATIONS

名称 Name	规格 Specification	
压缩机类型 Compressor type	全封闭型旋转压缩机 Hermetic Rotary Compressor	
泵体类型 Cylinder type	单缸 single cylinder	
气缸名义工作容积 Cylinder nominal Displacement	11.2cm ³ /rev	
冷冻油牌号 Brand of refrigerant oil	RB68EP	
冷冻油充注量 Refrigerant oil charge	280ml	
重量(含冷冻油)Weight(Refrigerant oil included)	8.5kg	
吸气管内径 Suction pipe I.D.	Φ9.65 ^{+0.15} ₀ mm	
排气管内径 Discharge pipe I.D.	Φ6.5 ^{+0.2} _{-0.1} mm	
电机类型 Motor type	单相电机 Single Phase Motor	
启动类型 Starting type	电容运转型 Permanent Split Capacitor	
极数 Pole	2 极 2 Pole	
额定输出功率 Rated output power	350W	
额定转速 Rated rotation speed	≥2860 rpm	
绕组电阻 Winding resistance (at 20℃)	主绕组 Main	辅绕组 Sub
	6.5Ω±10%	6.3Ω±10%
绝缘等级 Insulation class	B 级 B Class	
认证种类 Approval Type	CCC	

2.2 性能 PERFORMANCE

名称 Name	规格 Specification
制冷量 Capacity	≥1360×95% W (at 220V)
输入功率 Input power	≤505×105% W (at 220V)
能效比 C.O.P.	≥2.70×95% W/W (at 220V)
工作电流 Working current	≤2.5×105% A (at 220V)
堵转电流 L.R.A.	13A (at 220V)
噪音 (A 计权声压级噪音值) Noise(A weighed sound power)	≤58dB (A)

振动（切向加速度） Vibration(Tangential acceleration)		$\leq 25 \text{ m/s}^2$
最低启动电压 Minimum starting voltage		187V
运行电压 Running voltage		198~264V
压缩机开停次数 Compressor cycle		60000 次
气密性试验压力 Leak test pressure		2.12 MPa
残余水份含量 Residual moisture content		$\leq 100\text{mg}$
杂质含量 Impurity content		$\leq 40 \text{ mg}$
电气强度 Electrical strength		1500V 1min or 1800V 1sec
壳体耐压试验压力 Shell test pressure		7.42 MPa
绝缘电阻 Insulation resistance		$\geq 30 \text{ M}\Omega$
接地电阻 Grounding resistance		$\leq 0.1\Omega$
性能测试工况	测试电压/频率 Test Voltage / Frequency	220V ~ /50Hz/1Φ
	蒸发温度 Evaporating Temperature	12$^{\circ}\text{C}$
	冷凝温度 Condensing Temperature	60$^{\circ}\text{C}$
	液体温度 Liquid Temperature	51.7$^{\circ}\text{C}$
	吸气温度 Suction Temperature	30.3$^{\circ}\text{C}$
	环境温度 Ambient Temperature	35$^{\circ}\text{C}$
	测试风速 Testing air flow	0m/s
噪音（A 计权声压级噪音值）测试： Noise(A weighed sound power) method 采用“一点声压A计权测试法”。即过压缩机中心轴线和储液筒的中心线做一截面、并在压缩机轴线高度H（不含排气管）的1/2处，垂直于该截面1m处的位置进行噪音测试。		
振动（切向加速度）测试方法： Vibration(Tangential acceleration) method 采用GB/T15765中的三点切向加速度检测法。		

2.3 电气配件 ELECTRICAL COMPONENT

名称 Name	规格 Specification
运行电容 Running capacitor	17μF/450V·AC (用户自备 Self Provided)
过载保护器 Overload protector	B95-150-241C (外置 External)

2.4 过载保护器特性 OVERLOAD PROTECTOR PROPERTY

型号	温度特性 Open & Close Temp		动作时间特性 at 25 $^{\circ}\text{C}$ Short Time Trip		最小动作电流 特性 at 100 $^{\circ}\text{C}$ Ultimate Trip Current	生产厂家 Manufacturer
	动作温度 Open Temp.	复位温度 Close Temp.	电流 Test Amp.	动作时间 Trip Time.		
B95-150-241C	150\pm7$^{\circ}\text{C}$	65\pm11$^{\circ}\text{C}$	9.5 A	6~16s	3.06~4.14A	佛山通宝 Foshan TongBao

2.5 使用条件 APPLICATION CONDITION

名称 Name	规格 Specification
蒸发温度范围 Range of Evaporating Temperature	-3~22$^{\circ}\text{C}$

冷凝温度范围 Range of Condensing Temperature		45~65℃
最大压缩比 Maximum compression ratio		6
排气温度 Discharging Temperature		115℃ max
电机绕组温度 Motor winding Temperature		130℃ max
排气压力范围 Range of Discharge Pressure	标准条件 Standard load conditions	1.681 MPa
	过负荷 Overload conditions	2.418 MPa
吸气压力范围 Range of Suction Pressure	标准条件 Standard load conditions	0.443 MPa
	过负荷 Overload conditions	0.488 MPa

2.6 安装附件 MOUNTING ACCESSORIES

名称 Name	数量 Quantity	说明 Description
电器罩 Electric container cap	1	已配备 Loaded
六角法兰面螺母 Hexagon Flange Surface Nut	1	已配备 Loaded
橡胶垫 Rubber pad	1	已配备 Loaded
减振垫 Absorber support	3	客户自配 Not loaded
电容 Capacitor	1	客户自配 Not loaded
过载保护器 Overload protector	1	已配备 Loaded

2.7 压缩机相关图纸 COMPRESSOR RELATED DRAWINGS

名称 Name	代号 Symbol
压缩机外形图 Compressor shape diagram	YZ-DW-01
压缩机电气接线图 Compressor electric wiring diagram	YZ-DW-02
接地方式图 Compressor grounding method diagram	YZ-DW-03
电器罩图 Electric container cap diagram	AZ001-32301
六角法兰面螺母 Hexagon Flange Surface Nut	GB/T6177.1-2000-M5
橡胶垫图 Rubber pad diagram	YZG/AZ-00-15A
减振垫图 Absorber support diagram	YZG/AZ-00-01
过载保护器图 Overload protector diagram	B95-150-241C
铭牌图 Name plate diagram	YZ-DW-04
压缩机附件安装图 Accessories installation diagram	YZ-DW-05
压缩机运行范围图 Limitation of Operation diagram	YZ-DW-06
过载保护器性能曲线图 Overload Protector Performance diagram	YZ-DW-08

3、压缩机使用注意事项 COMPRESSOR CAUTIONS

3.1 橡胶塞 **Rubber plug**

压缩机内部已封入 0.05~0.08MPa (表压) 的干燥氮气, 使用时应先拔掉高压侧 (排气管) 的橡胶塞, 否则冷冻油会喷出压缩机。

Compressor is charged with 0.05~0.08MPa dry nitrogen, remove high pressure side (discharge tube side) rubber plug first before application, otherwise refrigerant oil will gush from the compressor.

3.2 焊接 **Welding**

压缩机与配管、配管与配管之间的焊接应注意绝不能让焊药、灰尘等杂质进入制冷系统。

Take care that the foreign matters like solder, dust, etc. will not get into the refrigerating system from soldering/welding joints between compressor and piping, as well as between piping.

3.3 抽真空 **Vacuum requirement**

压缩机不得自身抽真空及运转，系统抽真空应保证抽到真空度为 20Pa 以下。

The compressor should not be operated to from a vacuum and to absorb air; the evacuation of the system shall ensure that the vacuum is below 20Pa.

3.4 制冷剂 **Refrigerant**

使用本规格书中规定的制冷剂。

Use the refrigerant by the specification for compressor.

3.5 制冷剂充注 **Refrigerant charge**

制冷剂应从制冷系统冷凝器的尾端注入，而不能直接注入压缩机，当制冷剂超出规定值时，应同我公司联系。

Refrigerant should be charged from the end of the condenser of the refrigerating system. Never charge refrigerant to the compressor directly. When the charge amount exceeds designated value, contact us.

3.6 启动运行 **Starting or running**

压缩机启动运行前应确保接线正确，每两次启动时间间隔应在 3 分钟以上，绝对禁止压缩机反向运转和在空气中运行。

Make sure that wiring is correct before starting the compressor, the duration between two start-ups shall exceed three minutes, it is forbidden to run compressor in reverse direction and in the air.

3.7 杂质 **Impurity**

在装配系统时应保证系统洁净，为了防止毛细管等堵住，必须在制冷回路中装上过滤器。

Keep the system clean during assembly, the filter shall be assembled into the refrigerating loop to prevent block up of capillary tube etc.

3.8 冷冻油 **Refrigerant oil**

压缩机装入了规定的适量冷冻油，使用时不得增加或减少。

Do not reduce or increase the refrigerant oil during application as the compressor has been charged with specified amount of oil.

3.9 系统回油 **Oil return from the system**

为了保证制冷系统的油流回压缩机，在设计管路时气体的最小速度，水平管内为4m/s，垂直管内为7m/s。

To ensure the oil inside the refrigerating system returns to compressor, when designing the piping, the minimum gas velocity is 4m/s for horizontal pipe, and is 7m/s for vertical pipe.

3.10 制冷剂积蓄 **Refrigerant accumulating**

为了防止制冷剂液体积蓄在压缩机中，应保证压缩机壳体底部的温度大于冷凝温度5℃以上。

To prevent the liquid refrigerant accumulation in the compressor, ensure that the temperature at bottom of compressor case is more 5℃ than the condensing temperature.

3.11 运行电压波动范围 **Range of running voltage**

运行电压必须在额定电压的±10%范围之内。

The running voltage shall be within ±10% of the rated voltage.

3.12 运行频率允许范围 **Range of running frequency**

运行频率必须在额定频率的±2%范围之内。

The running frequency shall be within ±2% of the rated frequency.

3.13 运行时倾斜角 **Compressor installation requirement**

压缩机在倾斜角5°范围内可以正常运转。

The compressor shall operate properly with tilting angle below 5°.

3.14 存放 **Storage**

禁止压缩机横放、倒置、跌落，不要把压缩机放置在露天，必须将压缩机存放在-10℃~+65℃的室内。

Do not put the compressor horizontally or put it upside down. Do not let the compressor falls off. Do not put the compressor in the open air. Put the compressor inside the room where the temperatures inside range between -10℃~+65℃.

3.15 其他 **Other**

不得有水溅入压缩机内；压缩机打开吸排气盲塞后，R22 工质产品在空气中的时间不能超过 15 分钟（R410A,R134a 不超过 5 分钟）；当压缩机处于真空状态下，不得向密封接线柱上加电脉冲；在压缩机稳定运行时，系统内温度不应低于-35℃，以防止油中蜡的成分沉淀。

The compressor should not be splashed with water inside; The compressor should not be left open in the atmosphere for more than 15 minutes for R22 (Don't open in the air for more than 5 minutes for R410A and R134a) ;The electric pulse should not be applied to the hermetic terminals when the compressor is under vacuum; Temperature within system during stable compressor operation should not be less than -35℃ to prevent the wax in the oil from precipitation.

3. 16 规格书有效期 **The Period of Validity**

本规格书经贵公司确认之日后即生效，若更改必须重新确认生效，以前之规格书自动失效。

This document will take effect after the confirmation of your company with the authorized signature when design modification is approved by the customer, the current document is unavailable.

4、附件及图纸 **ACCESSORIES & DRAWINGS**

- 4. 1 压缩机外形图 **Compressor shape diagram**
- 4. 2 压缩机电气接线图 **Compressor electric wiring diagram**
- 4. 3 接地方式图 **Compressor grounding method diagram**
- 4. 4 电器罩图 **Electric container cap diagram**
- 4. 5 橡胶垫图 **Rubber pad diagram**
- 4. 6 减振垫图 **Absorber support**
- 4. 7 过载保护器图 **Overload protector diagram**
- 4. 8 铭牌图 **Name plate diagram**
- 4. 9 压缩机附件安装图 **Accessories installation diagram**
- 4. 10 压缩机运行范围图 **Limitation of Operation diagram**
- 4. 11 保护器性能曲线图 **Overload Protector Performance diagram**

名称 Name	压缩机外形图 Compressor shape	代号 Code	YZ-DW-01
---------	-------------------------	---------	----------

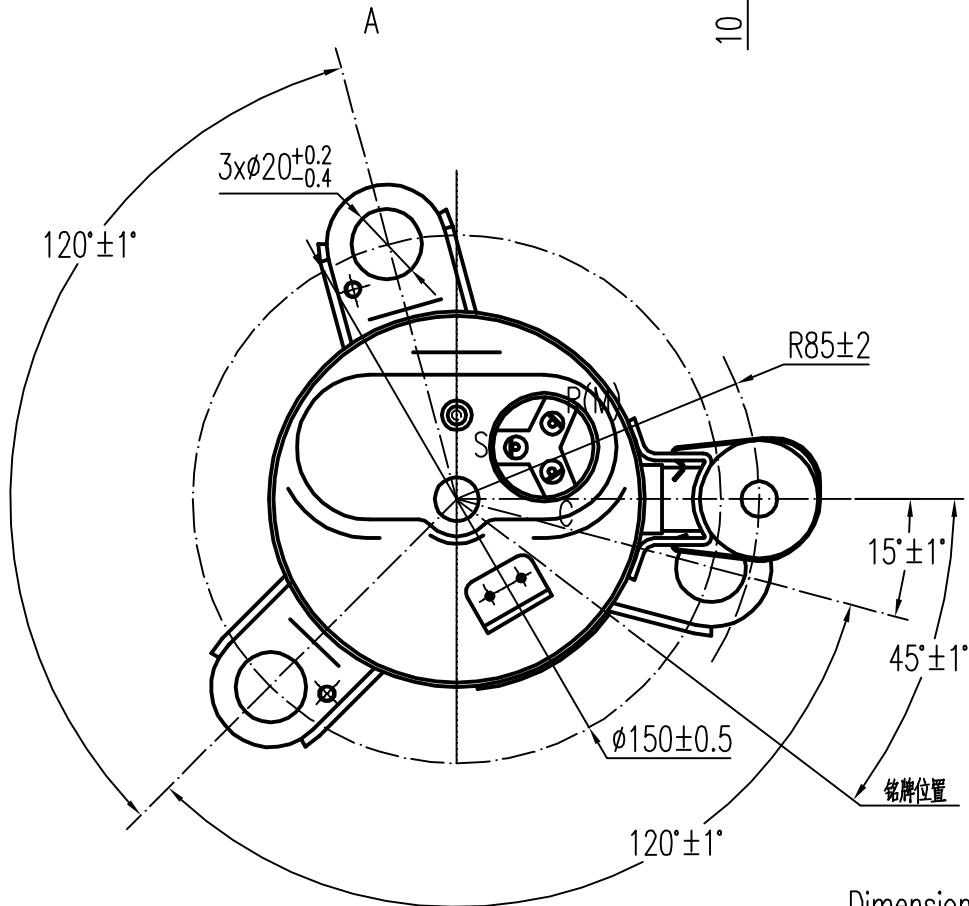
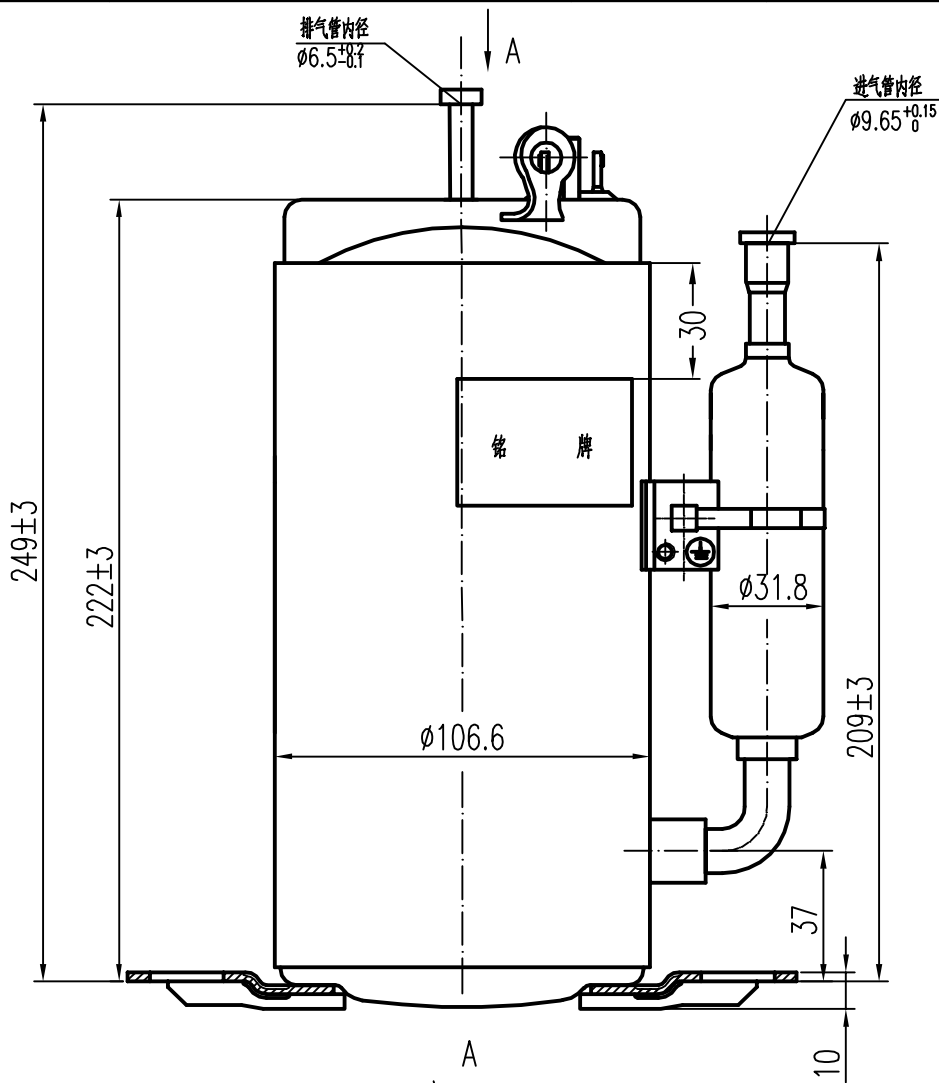

Dimension : mm

名称 Name	压缩机电气接线图 Compressor electric wiring diagram	代号 Code	YZ-DW-02
---------	---	---------	----------

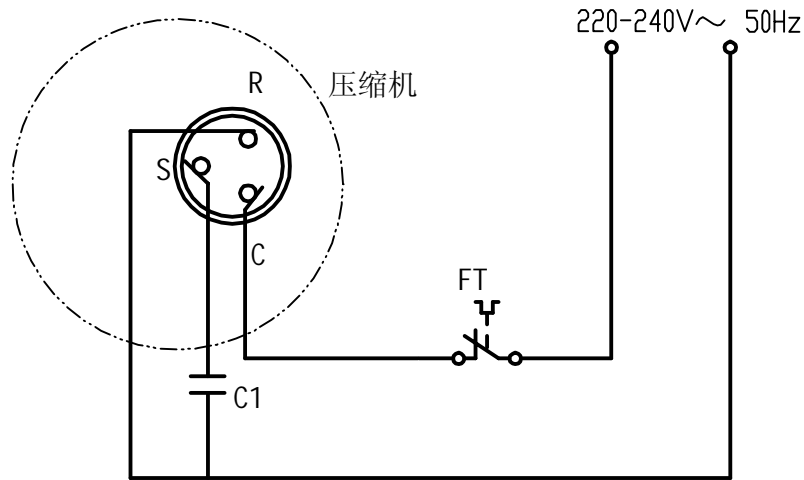

R 主绕组 Main winding S 辅绕组 starting winding
 C 公共绕组 Common winding C1 电容器 Capacitor
 注: FT1外置式保护器B95-150-241C安装在压缩机外。

名称 Name	接地方式图 Compressor grounding method diagram	代号 Code	YZ-DW-03
---------	---	---------	----------

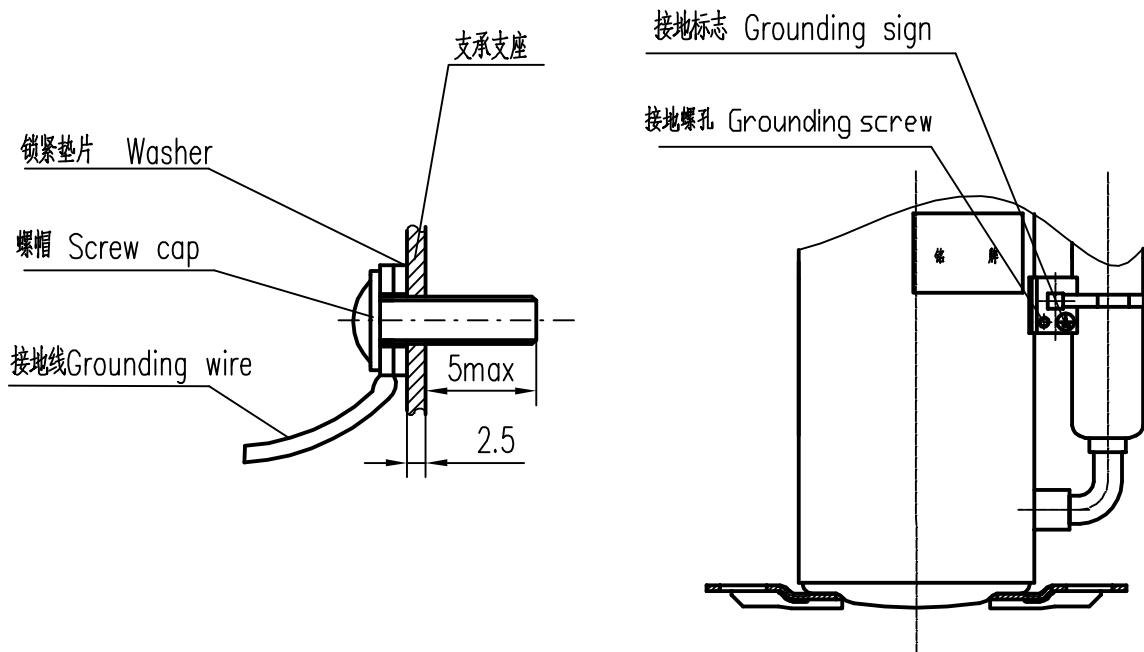

Dimension: mm

名称 Name	电器罩 Electric container cap diagram	代号 Code	AZ001-32301
---------	------------------------------------	---------	-------------

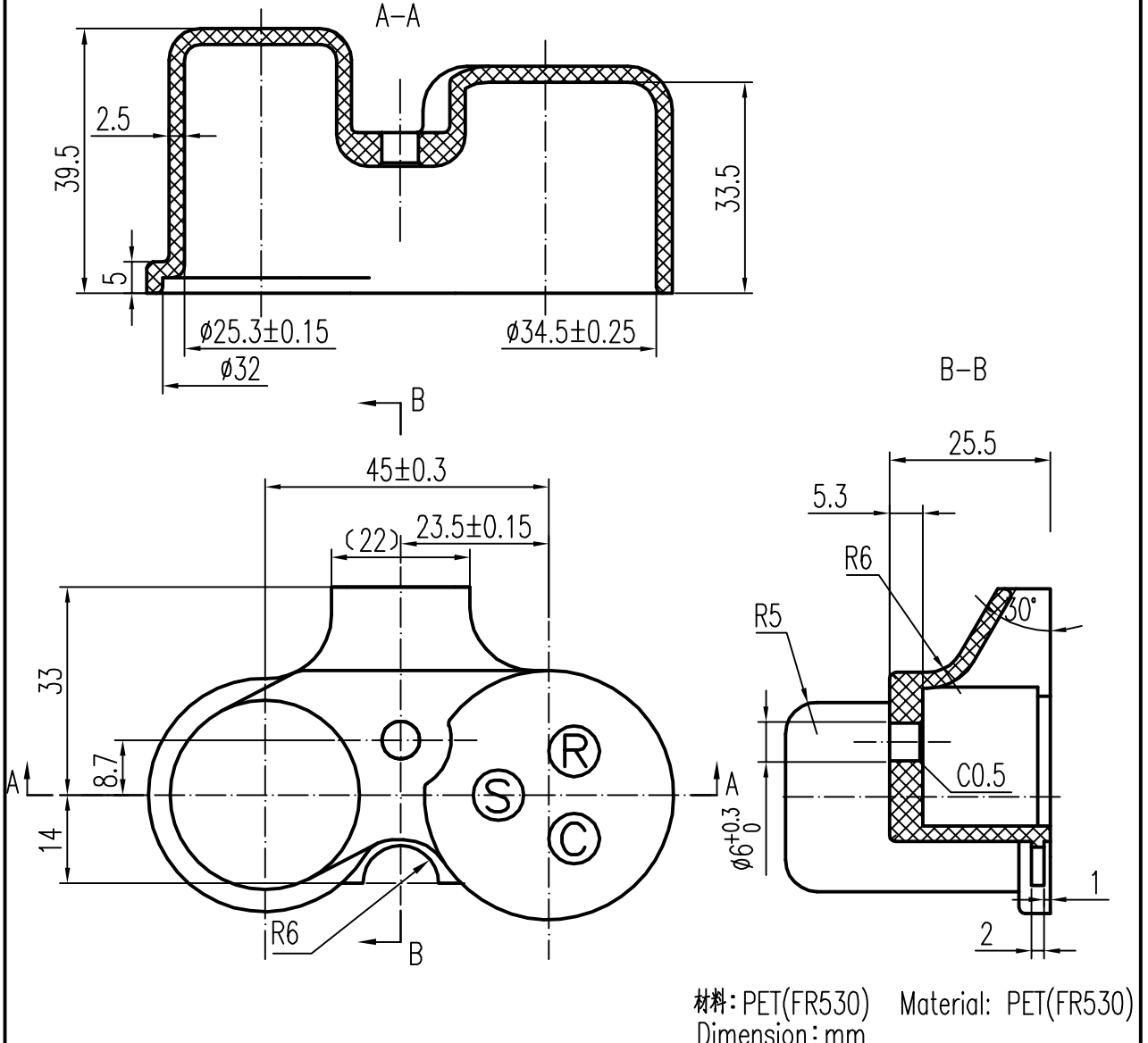

名称 Name	六角法兰面螺母 Hexagon flange surface nut	代号 Code	GB/T6177.1-2000-M5
---------	------------------------------------	---------	--------------------

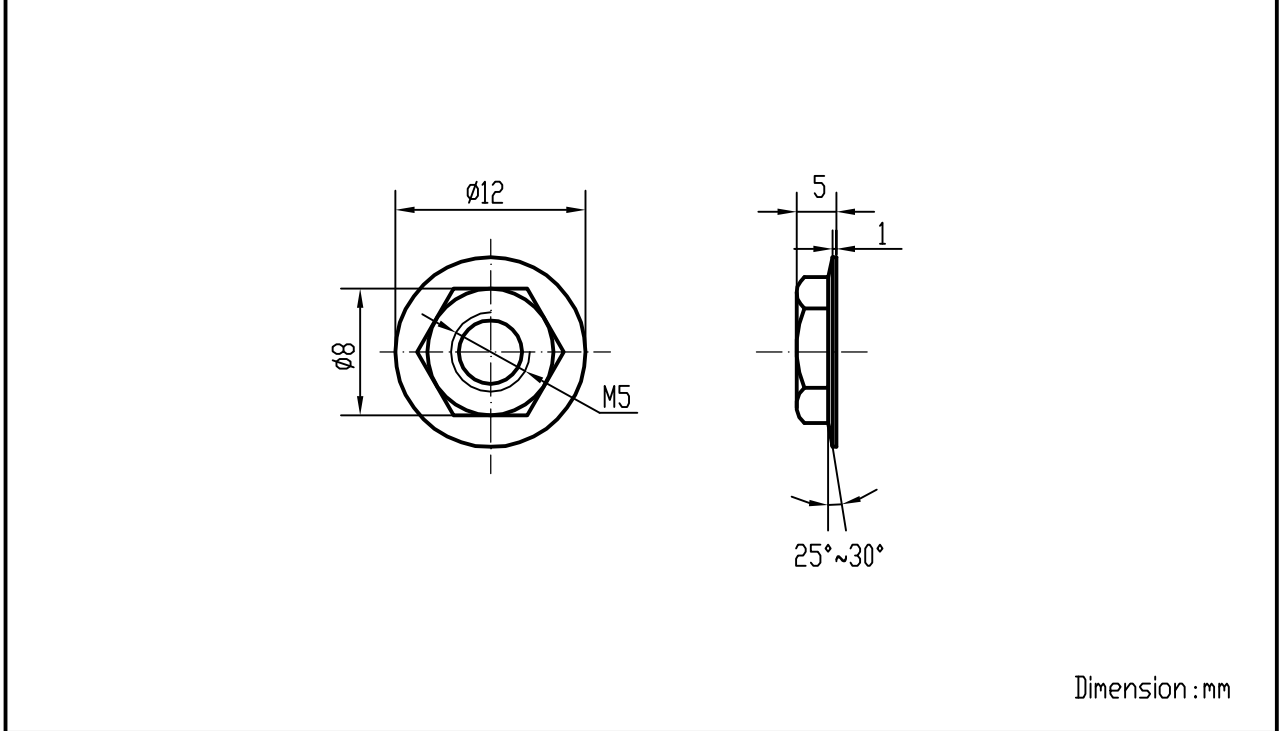

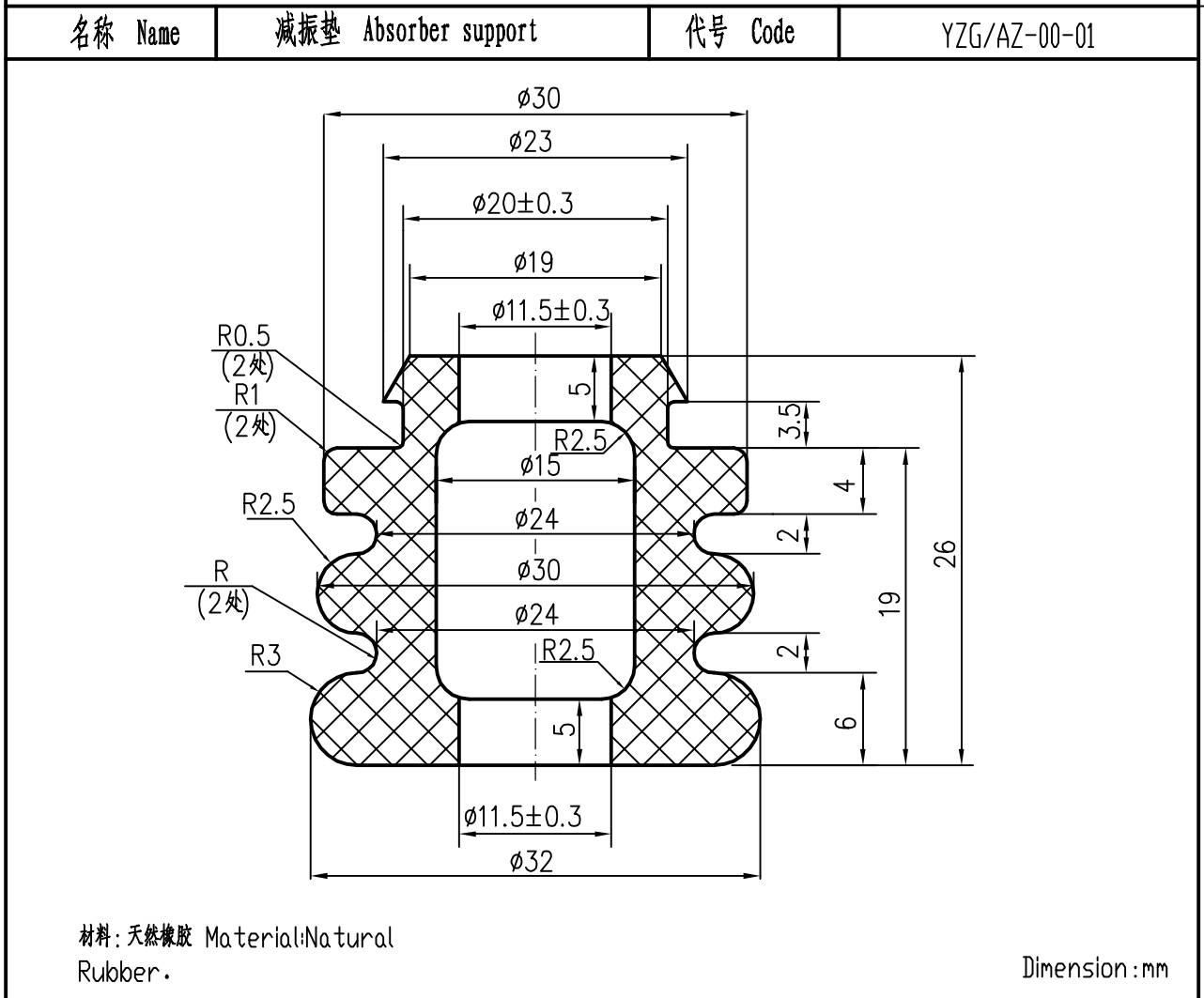
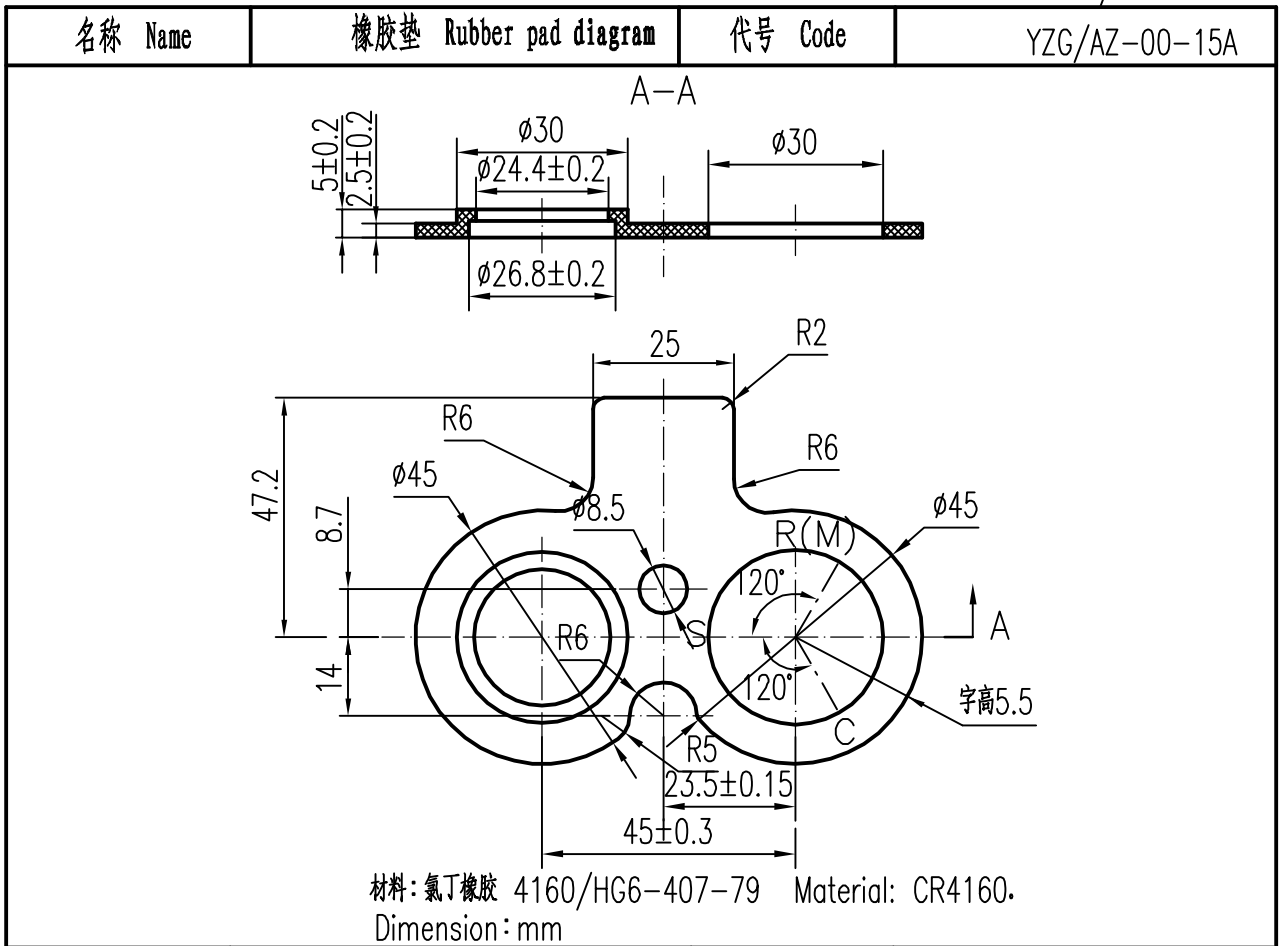

名称 Name	铭牌图 Name plate diagram	代号 Code	YZ-DW-04

名称 Name	过载保护器 Overload protector	代号 Code	B95-150-241C
---------	--------------------------	---------	--------------

温度特性 Open&Close Temp		动作时间特性 at 25℃ Short Time Trip		最小动作电流特性 at 100℃ Ultimate Trip Current	生产厂家 Manufacturer
动作温度 Open Temp.	复位温度 Close Temp.	电流 Test Amp.	动作时间(秒) Trip Time		
150±5℃	65±11℃	9.5A	6~16s	3.06~4.14A	佛山通宝 Foshan TongBao

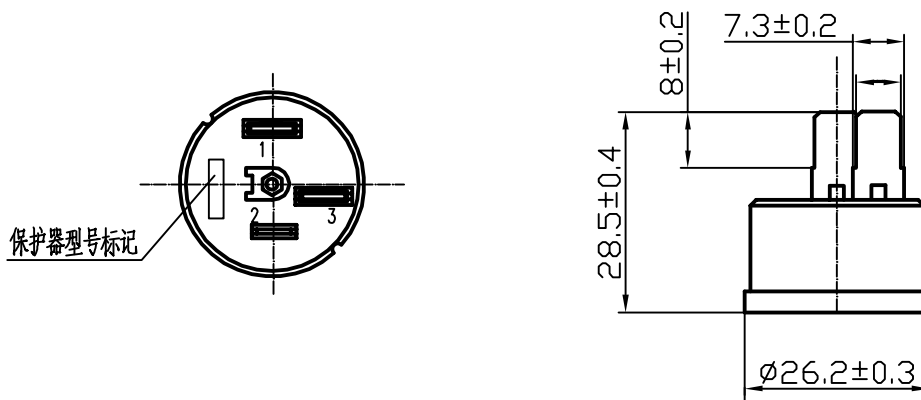

Dimension : mm

名称 Name	压缩机附件安装图 Accessories installation diagram	代号 Code	YZ-DW-05
---------	---	---------	----------

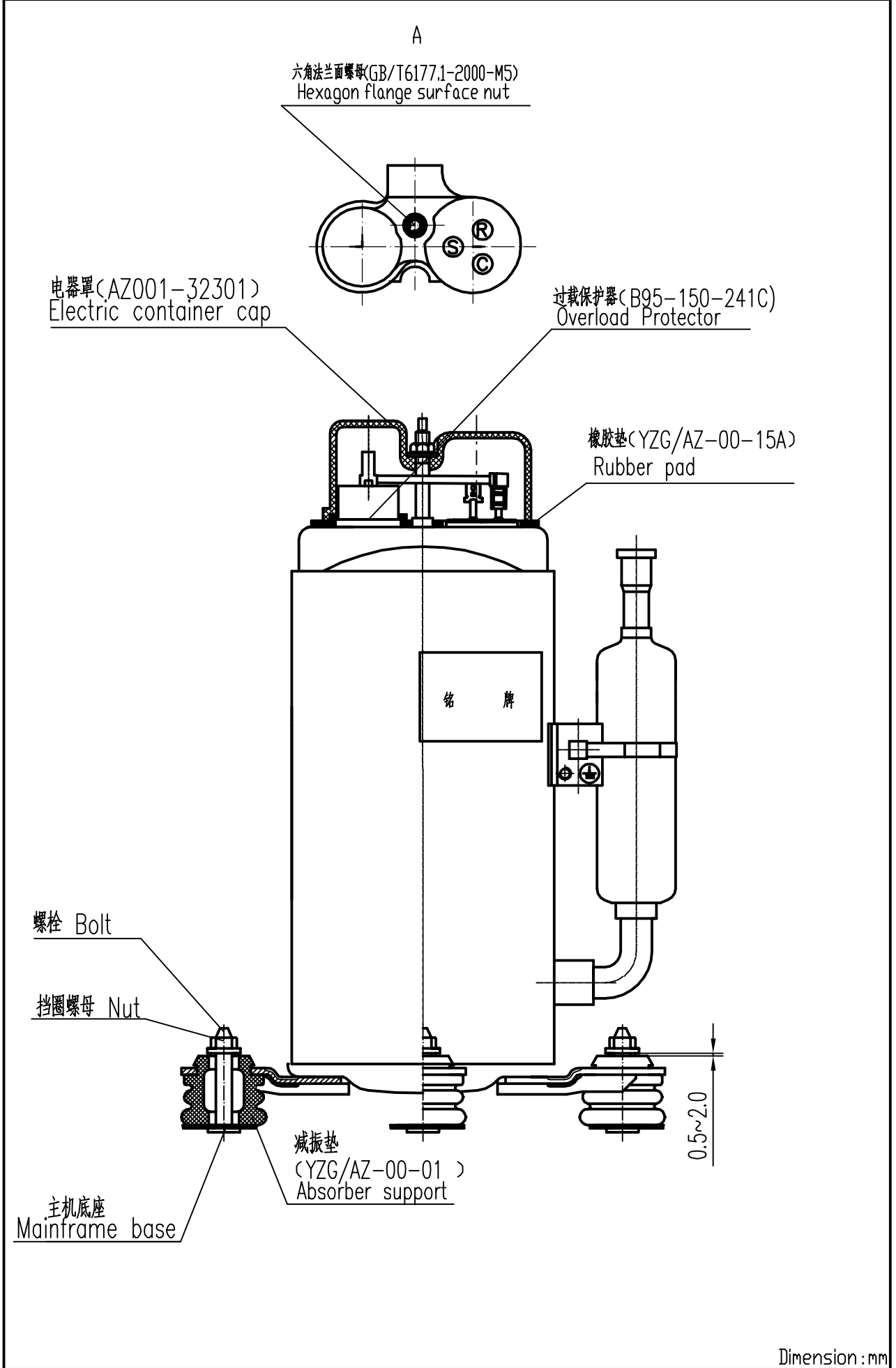

Dimension : mm

名称 Name	压缩机运行范围图 Limitation of Operation diagram	代号 Code	YZ-DW-06
---------	--	---------	----------

压缩机使用压力范围
LIMITATION OF OPERATION PRESSURE

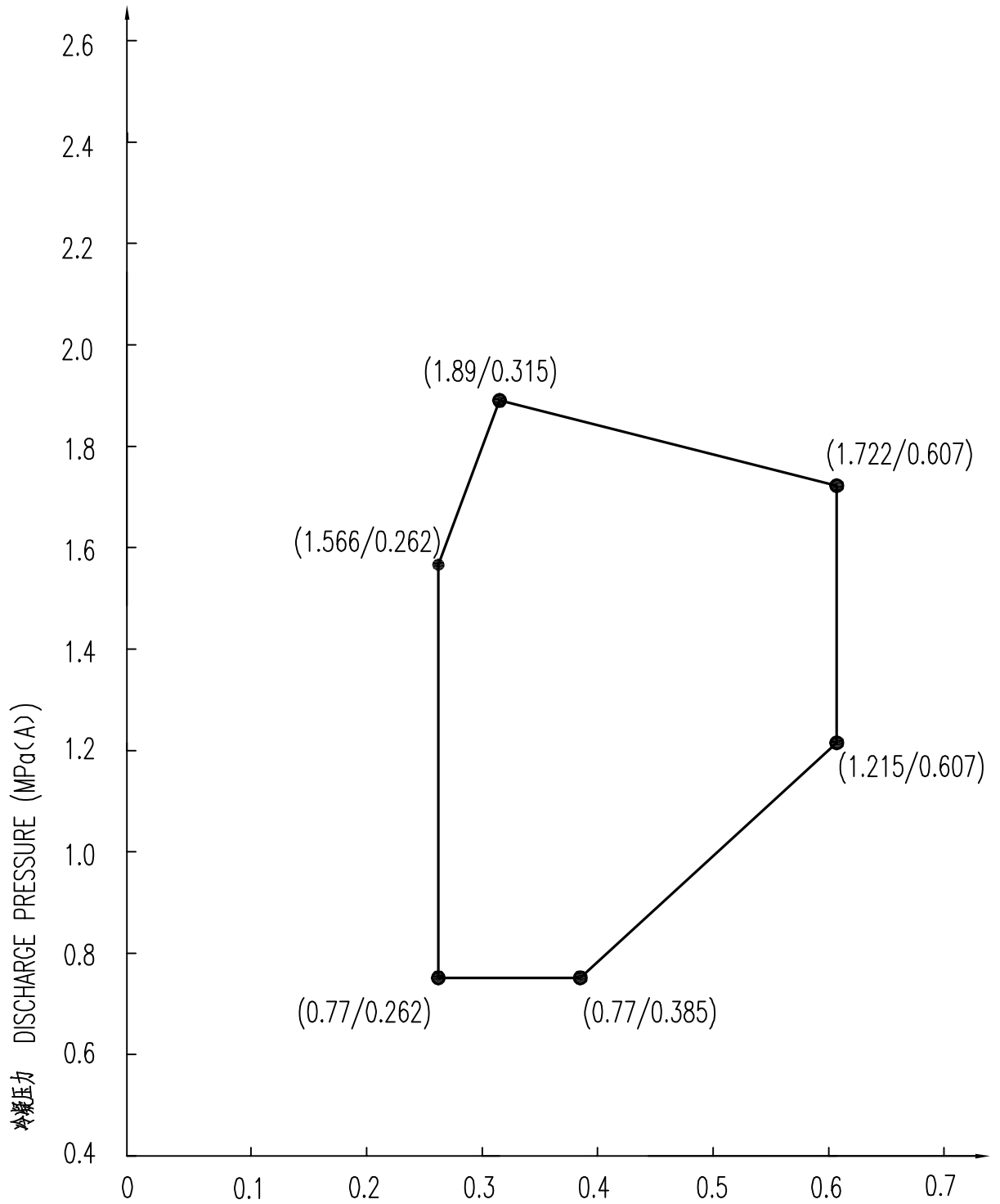

名称 Name	保护器曲线图 Overload Protector diagram	代号 Code	YZ-DW-08
---------	-----------------------------------	---------	----------

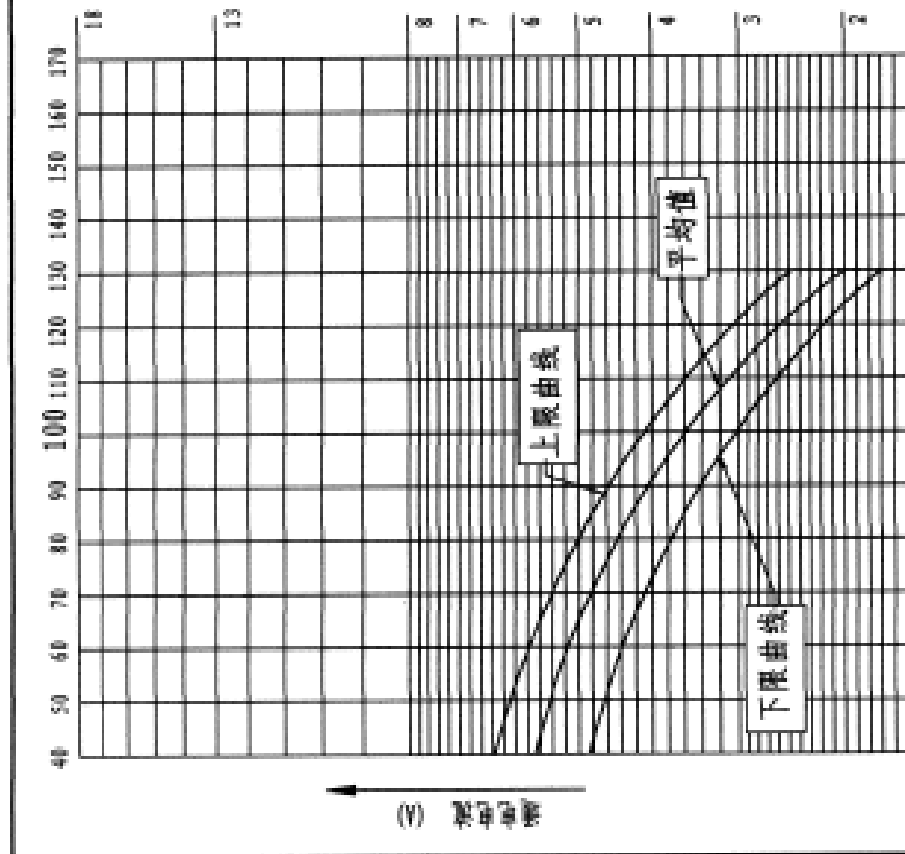
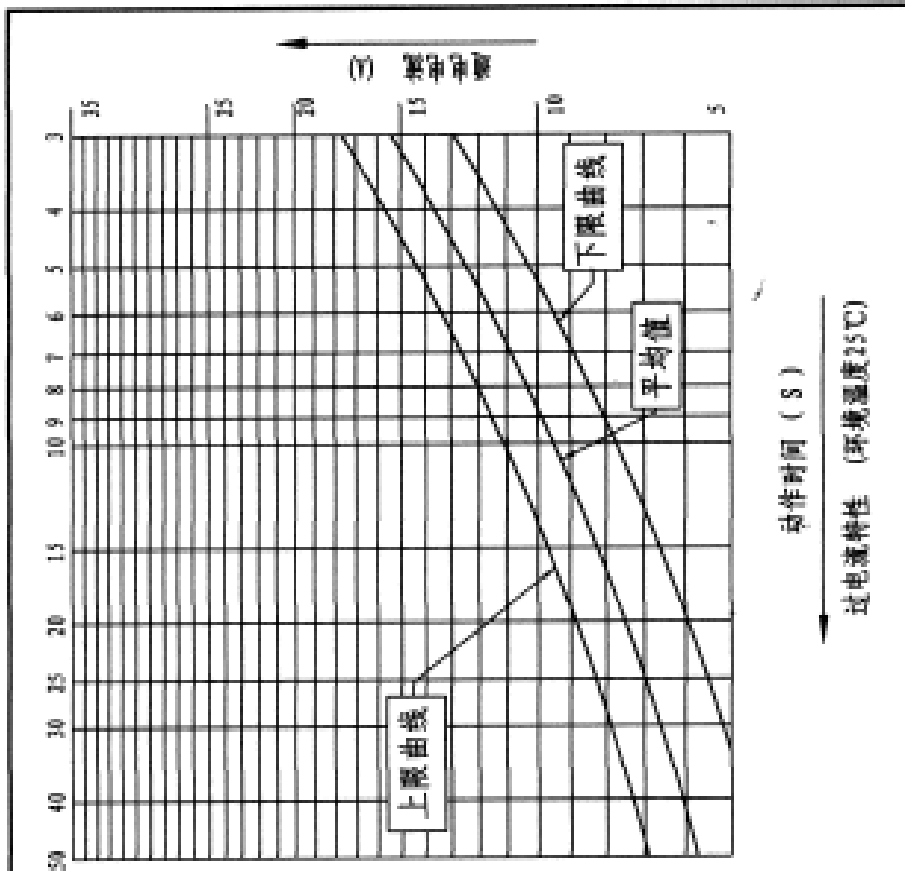

型号	B95-150-241C	日期	2011-5-20
备注		审核	
编制	张... / 5.20	审核	王... / 5.20

佛山通宝股份有限公司